



INSTALLATION INSTRUCTIONS

Accessory	Application	Publication No.
BACKREST (58 L) P/N 08L79-MKS-E00	CRF1100A/A2/A4/D/D2/D4	MII
		Issue Date
		April 2021

Accessory	Application	Publication No.
BACKREST (58 L) P/N 08L79-MKS-E00	CRF1100A/A2/A4/D/D2/D4	MII
		Issue Date
		April 2021

Accessory	Application	Publication No.
BACKREST (58 L) P/N 08L79-MKS-E00	CRF1100A/A2/A4/D/D2/D4	MII
		Issue Date
		April 2021

Honda Dealer: Please give a copy of these instructions to your customer.

PARTS LIST

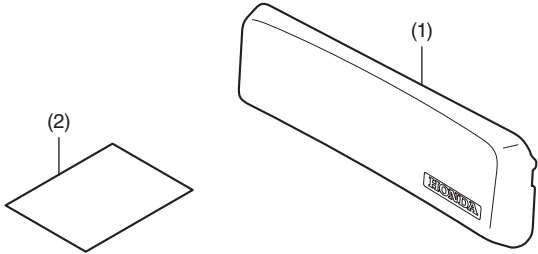

No.	Description	Qty
(1)	Backrest	1
(2)	URL paper	1

SUPPLIES REQUIRED

- Isopropyl alcohol
- Shop towel

INSTALLATION

NOTE:

- Heat the bonding surfaces with a hair dryer if the ambient air temperature is below 70°F (21°C).
- The adhesive reaches full strength in 72 hours. Wait at least 24 hours before riding your motorcycle.
- The surface of the backrest may turn white, but this is not a defective product.

When the surface of backrest turns white, wipe away with a shop towel or a like with water.

TOP BOX (58 L) Sold separately

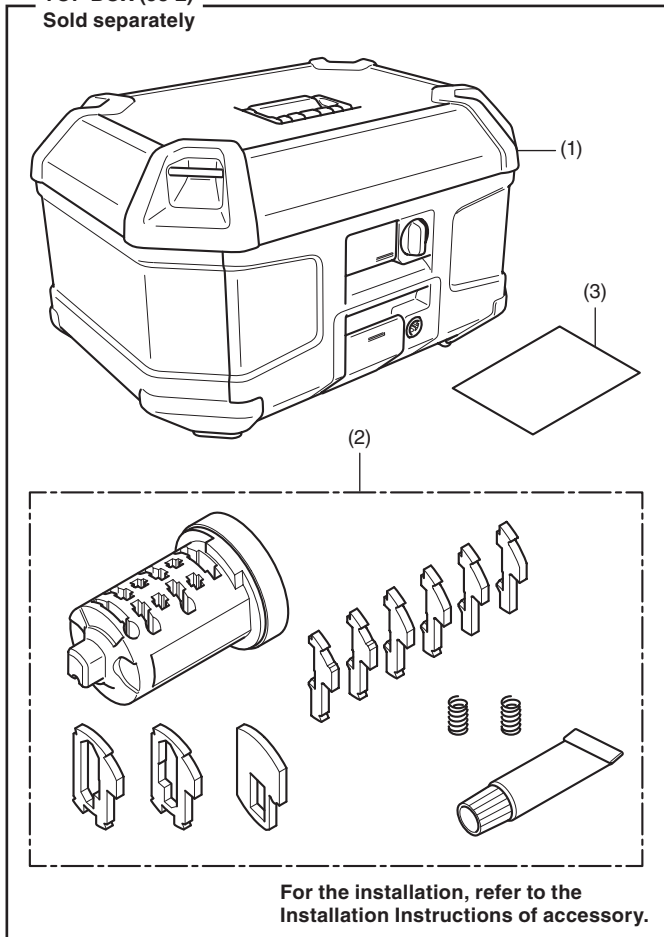

No.	Description	Qty
(1)	Top box	1
(2)	1 key inner cylinder (Wave key type)	1
(3)	URL paper	1

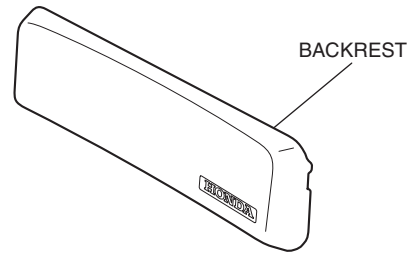

- Clean the surface of the area shown using an isopropyl alcohol.

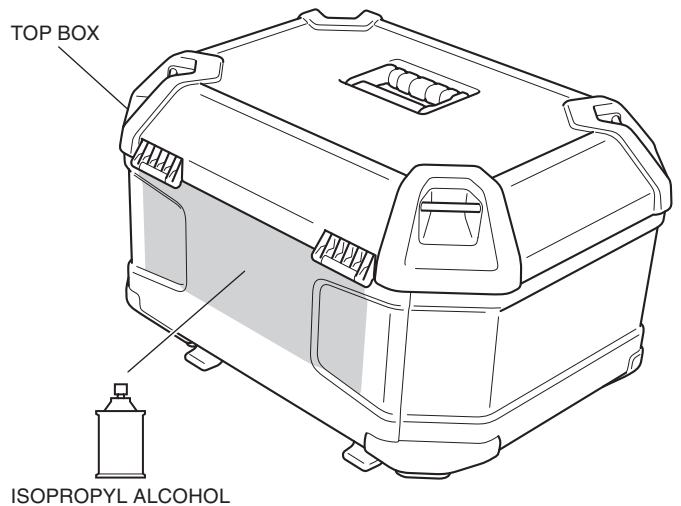

2. Peel off the adhesive backing on the backrest as shown.

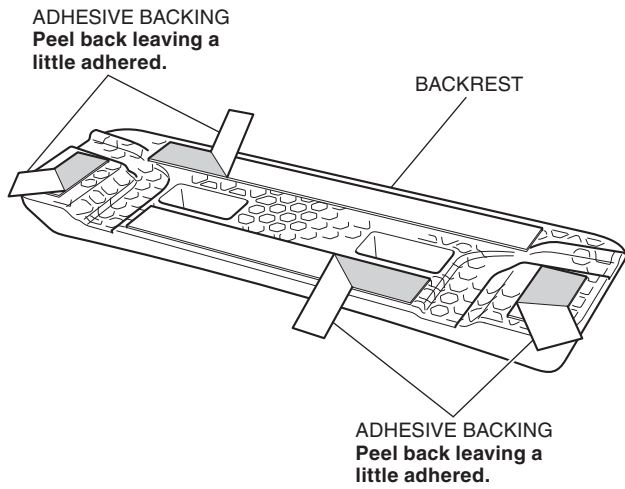

3. Attach the backrest as shown.
- **Align the backrest with the shape of the top box.**

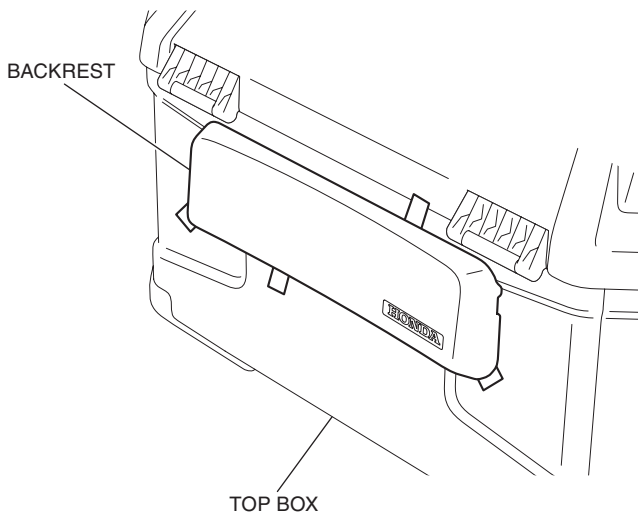

4. Remove the adhesive backing as shown.

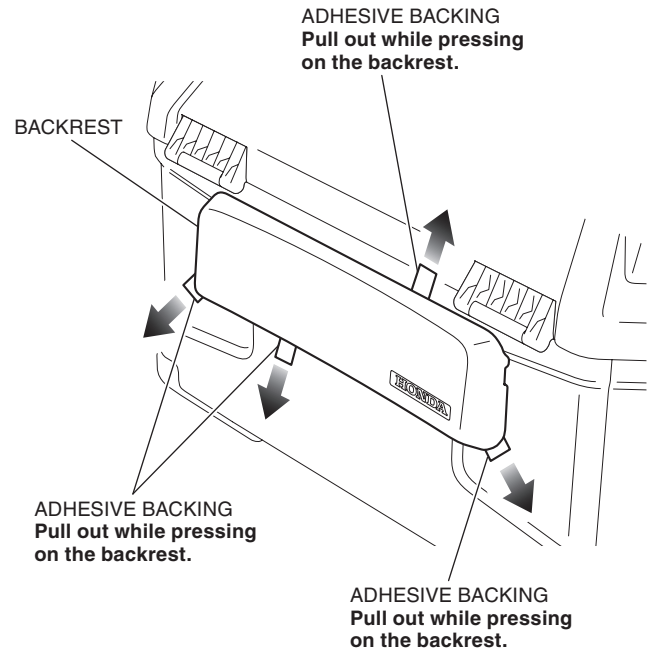

5. Apply adequate pressure to the attached backrest.